

CRT-52-SS KIT SERIES

INSTRUCTION SHEET

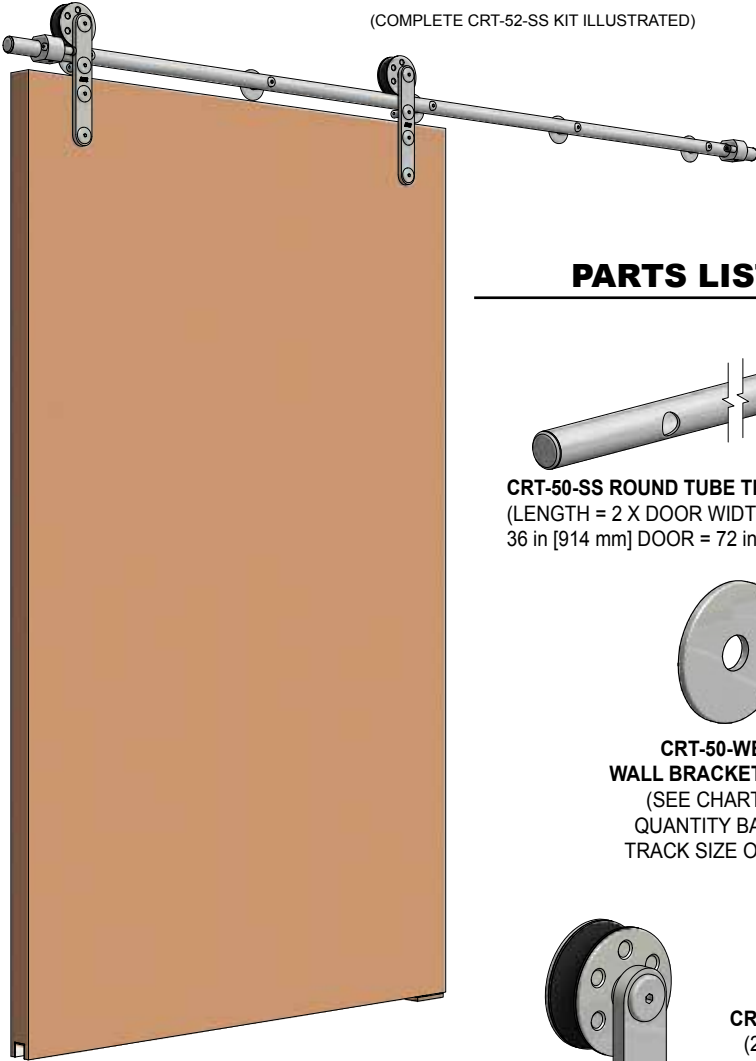

(COMPLETE CRT-52-SS KIT ILLUSTRATED)



CROWDERTRACK'S CRT-52-SS SERIES SYSTEM

- LOAD CAPACITY 150LBS. (TWO HANGERS)
- EXPOSED STAINLESS STEEL HARDWARE
- SHOCK ABSORBING STOPS
- DELRIN WHEEL WITH PRECISION GROUND BALL BEARINGS.
- CRT-52-SS KITS ARE SUPPLIED WITH C-914 GUIDE CHANNEL AND C-913 FLOOR GUIDE

PARTS LIST (FOR STANDARD CRT-52-SS 1DR KIT)

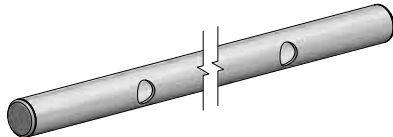

CRT-50-SS ROUND TUBE TRACK X LENGTH (1)
(LENGTH = 2 X DOOR WIDTH, EXAMPLE:
36 in [914 mm] DOOR = 72 in [1829 mm] TRACK)



CRT-50-WBN-SS WALL BRACKET NUT (X)
(SEE CHART A FOR QUANTITY BASED ON TRACK SIZE ORDERED)



CRT-22-WBS-SS WALL BRACKET SPACER (X)
(SEE CHART A FOR QUANTITY BASED ON TRACK SIZE ORDERED)



CRT-50-WBP-SS WALL BRACKET PLATE (X)
(SEE CHART A FOR QUANTITY BASED ON TRACK SIZE ORDERED)



5/16" X 4" LONG HANGER BOLTS (X)
(SEE CHART A FOR QUANTITY BASED ON TRACK SIZE ORDERED)

SEE CRT-52-SS INSTRUCTION SHEET FOR QUANTITY BASED ON TRACK SIZE ORDERED

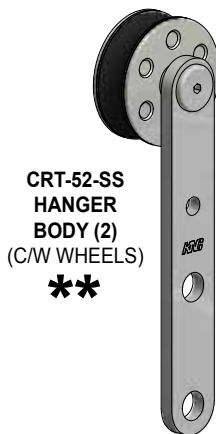

CRT-52-SS HANGER BODY (2)
(C/W WHEELS)



CRT-50-CB-SS BOLT (10)
(2 C/W LOCTITE TAPE FOR ANTI-LIFT)



CRT-52-DR-SS DOOR ROD (4)
(FOR 1 3/4 in [44.5 mm] DOORS ONLY)



CRT-50-AL-SS ANTI-LIFT PIECE (2)



CRT-50-SS SHOCK ABSORBING STOPS (2)

IF ORDERED CRT-52-38-SS KIT FOR 1 3/8 in [34.9 mm] DOORS

CRT-52-DR-SS DOOR ROD (4) ARE REPLACED WITH:

**** CRT-52-DR38-SS DOOR ROD (4)**
(FOR 1 3/8 in [34.9 mm] DOORS ONLY)

FOR 2DR KITS: PARTS THAT SHOW ** QUANTITIES ARE DOUBLED

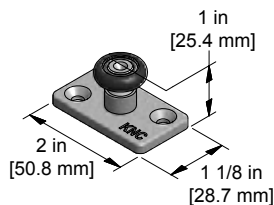

C-913 FLOOR GUIDE (1)



#10 X 1-3/4" FLATHEAD SCREWS (2)

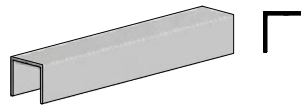

C-914 GUIDE CHANNEL X LENGTH (1)
(LENGTH = DOOR WIDTH, EXAMPLE: 36 in [914 mm] DOOR = 36 in [914 mm] GUIDE CHANNEL)



#8 X 3/4" PAN HEAD SCREWS (4)

A PRODUCT OF K.N. CROWDER MFG. INC

K.N. Crowder Mfg. Inc. • 1220 Burloak Drive • Burlington, Ontario, Canada • L7L 6B3 **K.N. Crowder Inc.** • 210 Eighth Street South • Lewiston, New York • 14092
TOLL-FREE PHONE: 1-866-999-1KNC (1562) • TOLL-FREE FAX: 1-800-567-0123 • WEBSITE: www.kncrowder.com • EMAIL: customerservice@kncrowder.com

© 2014 K.N. CROWDER MFG. INC. All Rights Reserved.

CRT-52-SS KIT DETAILS (CRT-52-SS HANGER FOR 1 3/4 in [44.5 mm] THICK DOORS, C-914/C-913 GUIDE SYSTEM)

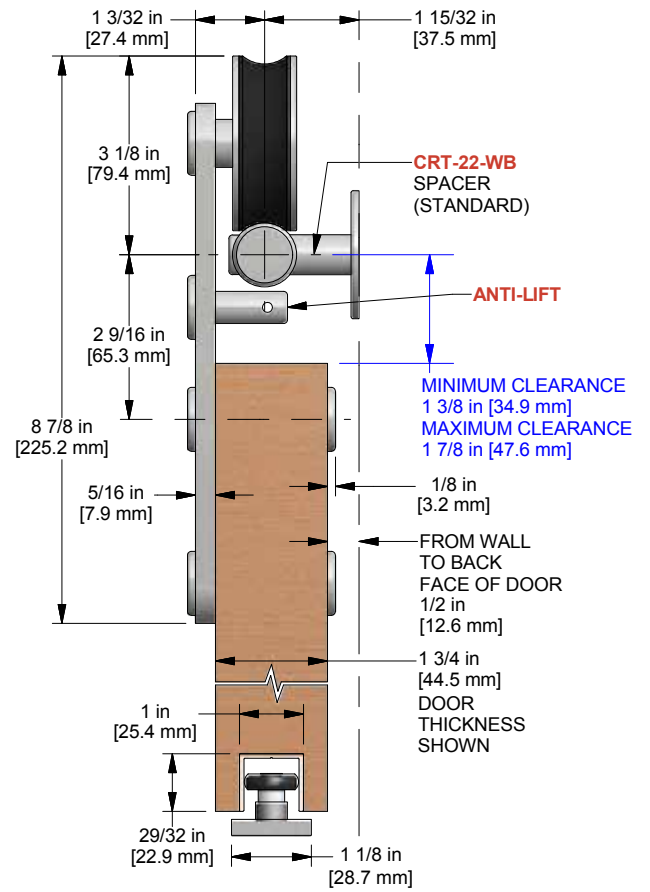
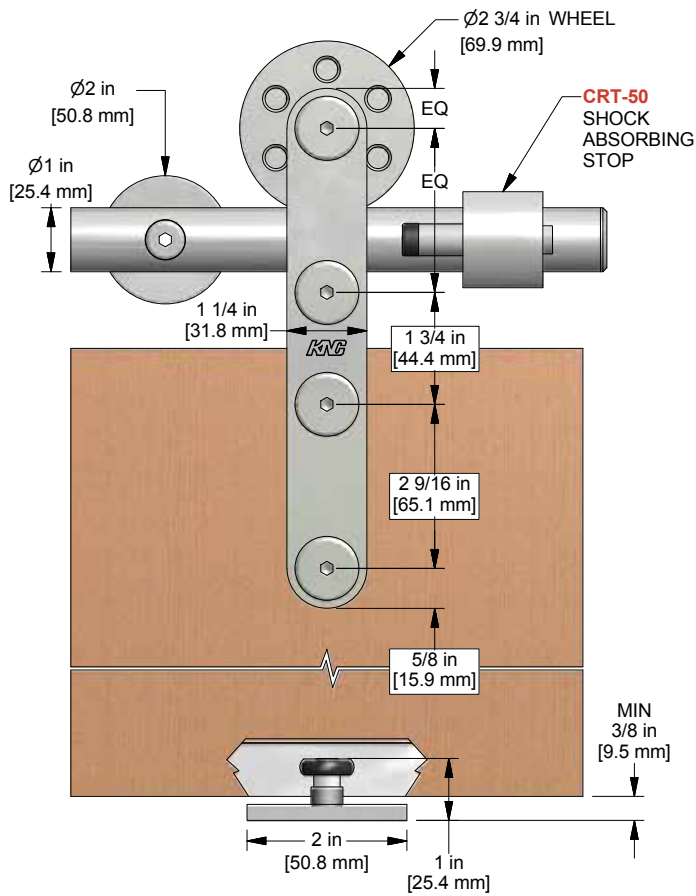

CRT-52-38-SS KIT DETAILS (CRT-52-38-SS HANGER FOR 1 3/8 in [34.9 mm] THICK DOORS, C-914/C-913 GUIDE SYSTEM)

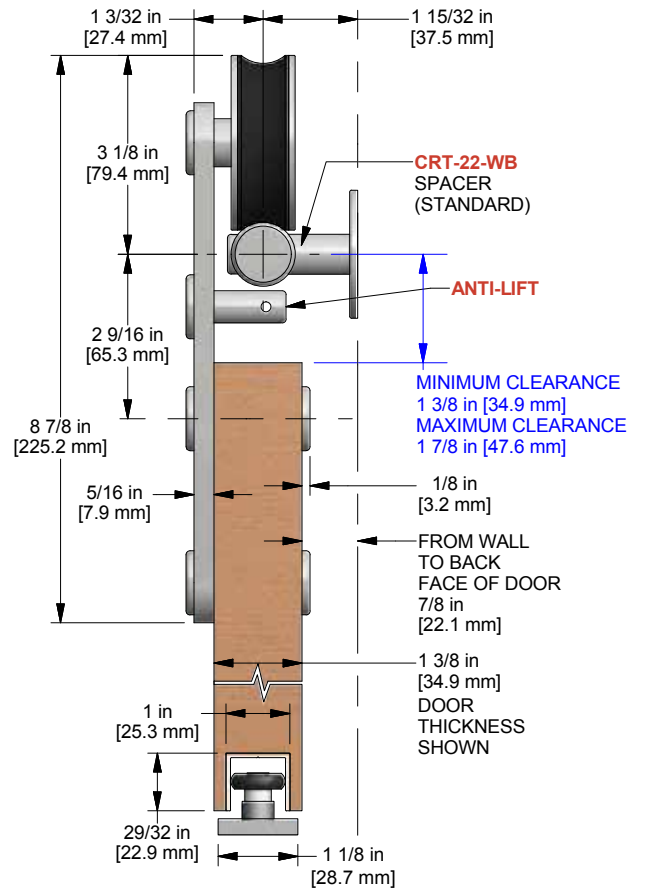
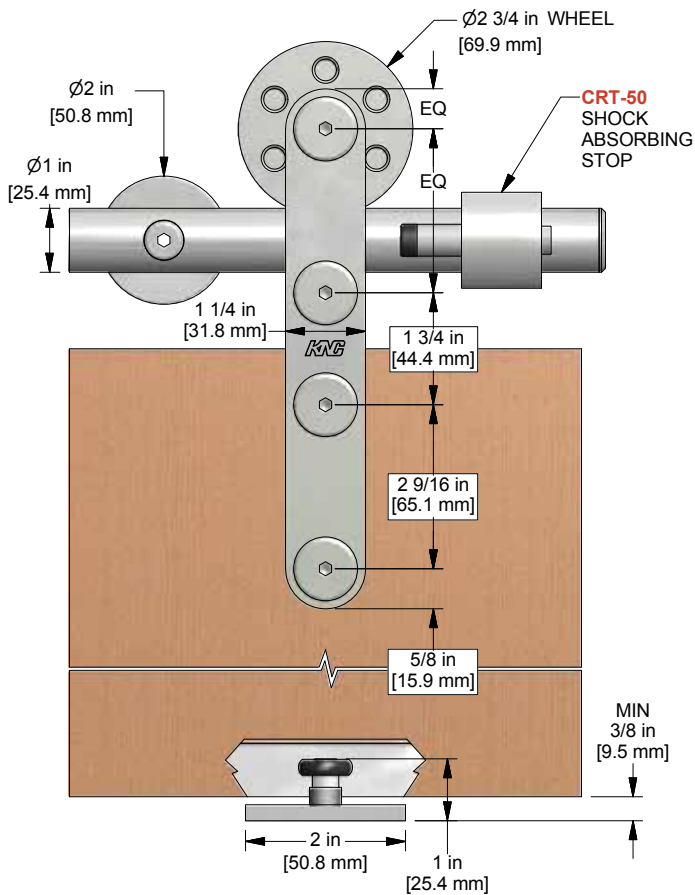

ELEVATION VIEW OF COMPLETE INSTALLATION

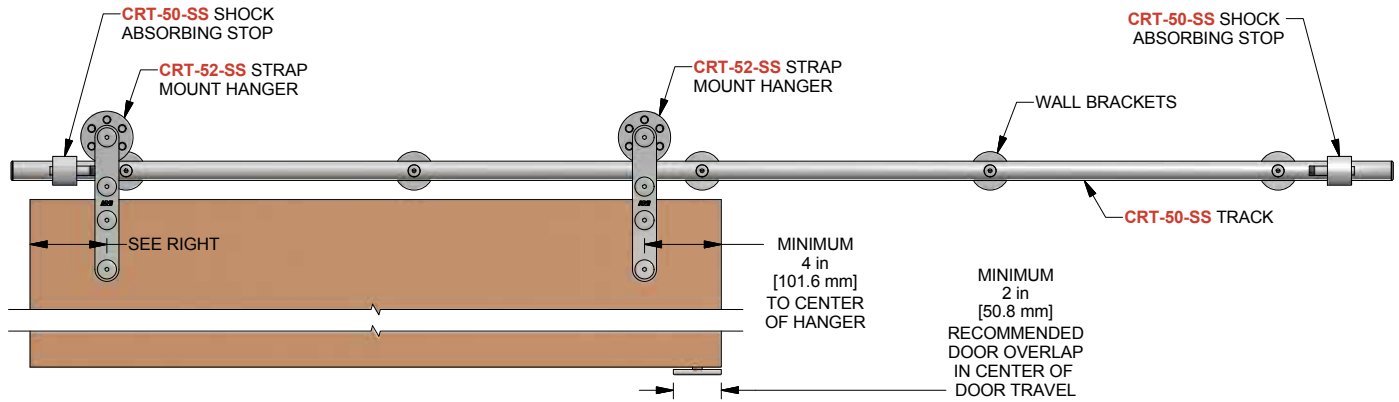

STEP #1:

DETERMINE OPENING SIZE, DOOR SIZE AND TRACK POSITIONING ON WALL AND CLEARANCE REQUIRED AT TOP AND BOTTOM OF DOOR BASED ON DIMENSIONS SHOWN IN DETAIL VIEWS ON THE PREVIOUS PAGE. TRACK SHOULD BE AT LEAST TWO TIMES DOOR WIDTH. EXAMPLE: 36 in [914 mm] DOOR REQUIRES AT LEAST A 72 in [1829 mm] TRACK LENGTH. TRACKS ARE ONLY AVAILABLE IN PER FOOT INCREMENTS AND IT IS NOT RECOMMENDED TO CUT THE TRACK DOWN ON SITE AS THE CRT-50-SS TRACK FEATURES PRESS-FITTED END CAPS THAT CANNOT BE EASILY REMOVED WITHOUT DAMAGING THE END CAPS OR THE TRACK.

STEP #3:

MARK A HORIZONTAL LINE WITH A LEVEL ON THE WALL AT THE MEASUREMENT CALCULATED IN STEP 2. LOCATE TRACK ON WALL AND MARK HOLE LOCATIONS AS PER THE SPACING STANDARDS BASED ON TRACK LENGTHS FOUND IN CHART A ON THE TEMPLATE SHEET OR WITH THE TRACK ON SITE. ONCE THE HOLE LOCATIONS ARE MARKED, IF USING THE STANDARD 5/16" HANGER BOLTS SUPPLIED WITH KIT, PRE-DRILL A Ø7/32 in [5.8 mm] HOLE INTO THE WOOD SUPPORT AT LEAST 2 in [50.8 mm] DEEP. IF THERE IS DRYWALL PRESENT, RE-DRILL A Ø5/8 in [15.9 mm] CLEARANCE HOLE IN THE DRYWALL PORTION OF THE HOLES ONLY. SEE ILLUSTRATIONS BELOW FOR ASSISTANCE.

!!!ATTENTION!!!

CRT-50 SERIES TRACKS MUST BE MOUNTED ON SOLID BACKING/SUPPORT IN THE WALL (BEHIND DRYWALL IF APPLICABLE). FAILURE TO PROVIDE BACKING MAY CAUSE SYSTEM FAILURE OR SAGGING OF THE TRACK/DOOR.

STEP #2:

ONCE DOOR SIZE HAS BEEN DETERMINED, CALCULATE THE DISTANCE FROM THE FINISHED FLOOR TO THE CENTER OF THE TRACK WITH THE FOLLOWING INFORMATION AND FORMULA:

MINIMUM CLEARANCE AT THE BOTTOM FOR THE C-914 GUIDE CHANNEL AND C-913 GUIDE IS 3/8 in [9.5 mm]

MINIMUM CLEARANCE FROM CENTER OF TRACK TO TOP OF DOOR IS 1 3/8 in [34.9 mm]

MAXIMUM CLEARANCE FROM CENTER OF TRACK TO TOP OF DOOR IS 1 7/8 in [47.6 mm]

FORMULA:

(NET DOOR HEIGHT) + (CLEARANCE AT BOTTOM) + (CLEARANCE AT TOP) = DISTANCE FROM FINISHED FLOOR TO CENTER OF TRACK.

EXAMPLE: ASSUMING 84 in [2134 mm] HIGH DOOR, 1/2 in [12.7 mm] CLEARANCE AT THE BOTTOM & 1 1/2 in [38.1 mm] CLEARANCE AT THE TOP

CALCULATION BASED ON EXAMPLE ABOVE:

(84 in [2134 mm]) + (1/2 in [12.7 mm]) + (1 1/2 in [38.1 mm]) = 86 in [2184 mm] FROM FINISHED FLOOR TO CENTER OF TRACK

!!!ATTENTION!!!

PLEASE REVIEW SUPPORT AND ANCHOR TYPES REQUIRED AS THE KITS ARE ONLY SUPPLIED WITH LAG SCREWS. MASONRY OR CONCRETE ANCHORS ARE TO BE SUPPLIED BY OTHERS.

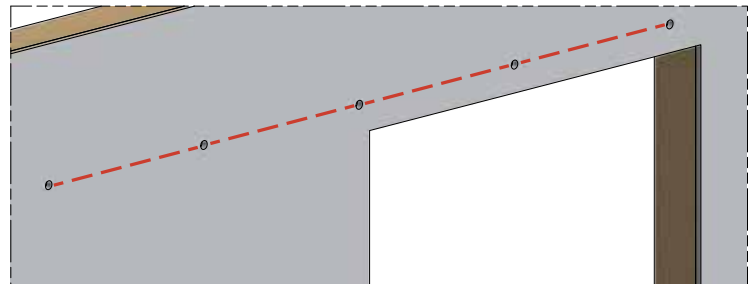
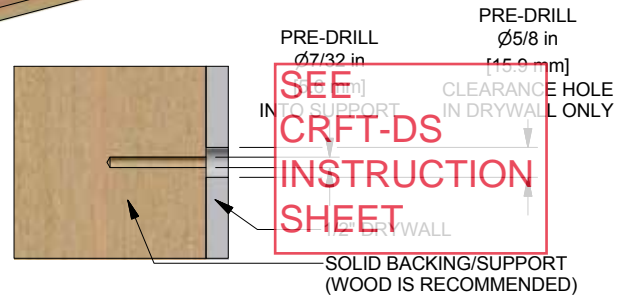
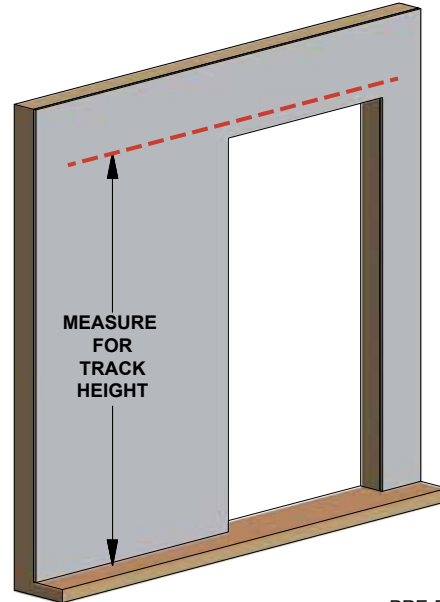

STEP #4:

ASSEMBLE THE CRT-50-WBN WALL BRACKET NUTS WITH THE 5/16" HANGER BOLTS THAT ARE SUPPLIED WITH THE KITS. ONE WALL BRACKET NUT FOR EACH HANGER BOLT. CRT-50-WBN WALL BRACKET NUT SHOULD BE THREADED ONTO THE MACHINE THREAD END, NOT THE LAG END OF THE HANGER BOLTS.

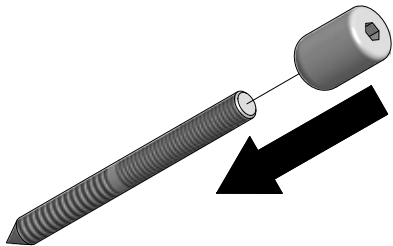

STEP #5:

INSTALL TRACK ONTO WALL WITH THE NECESSARY COMPONENTS AND IN THE ORDER AS SHOWN BELOW. THE ILLUSTRATIONS BELOW ARE BASED ON DRYWALL APPLICATION.

NOTE: ENSURE TRACK IS LEVELED AND FULLY SECURED TO THE SUPPORT.

NOTE: IF INSTALLING A 2DR KIT, REVIEW STEP #13 FOR INSTALLING THE STOPS IN THE MIDDLE OF THE TRACK AS THIS WILL NOT BE ACCESSIBLE ONCE THE TRACK IS INSTALLED ON THE WALL.

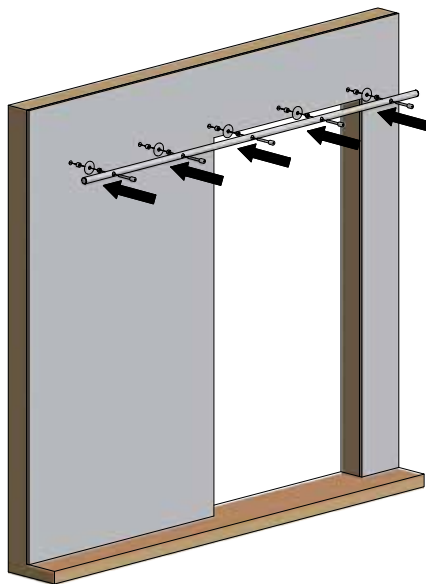

STEP #6:

PREPARE THE DOOR FOR MOUNTING THE CRT-52-SS STRAP MOUNT HANGERS. MINIMUM HOLE SIZE IN DOOR MUST BE Ø5/8 in [16.0 mm]. SEE DIMENSION DETAILS, AND TEMPLATE ON LAST PAGE OF THIS INSTRUCTION SHEET FOR THE HOLE LOCATIONS. IT IS RECOMMENDED TO MOUNT THE HANGERS MINIMUM 4 in [101.6 mm] FROM EACH EDGE OF THE DOOR TO THE CENTER OF THE HANGERS AS PER THE DETAILS AND TEMPLATE IN THIS INSTRUCTION SHEET.

NOTE: FULL SCALE TEMPLATE IS PROVIDED ON THE LAST PAGE OF THIS INSTRUCTION SHEET BOOKLET.

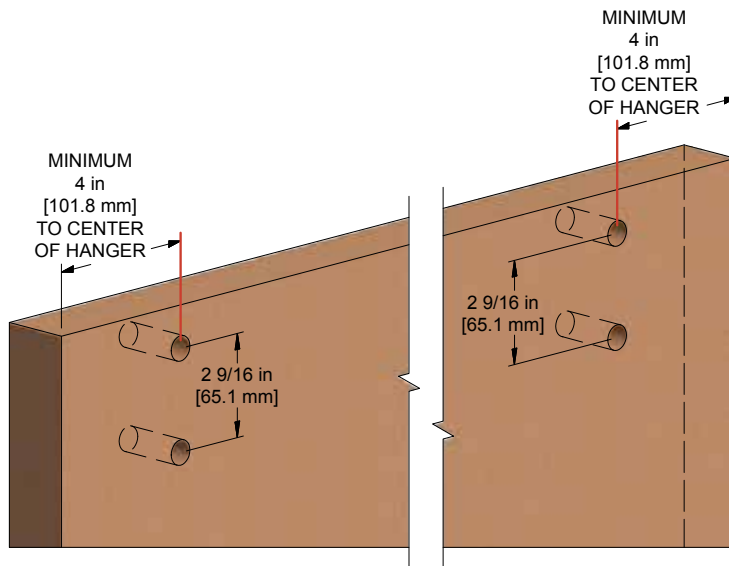

STEP #7:

PREPARE BOTTOM OF DOOR BASED FOR THE GUIDE CHANNEL. **AESTHETIC NOTE: IF SUFFICIENT OVERLAP OF THE DOOR IS PROVIDED, GUIDE CHANNEL CAN BE RECESSED INTO THE DOOR WITHOUT CUTTING A SLOT THE FULL LENGTH OF THE DOOR. IF GUIDE CHANNEL WILL BE INSTALLED SHORT FROM THE EDGES, IT IS RECOMMENDED TO HAVE AT LEAST 1/2" [12.7 mm] DOOR MATERIAL AT EACH END OF THE DOOR BEFORE THE START OF THE GUIDE CHANNEL SLOT.**

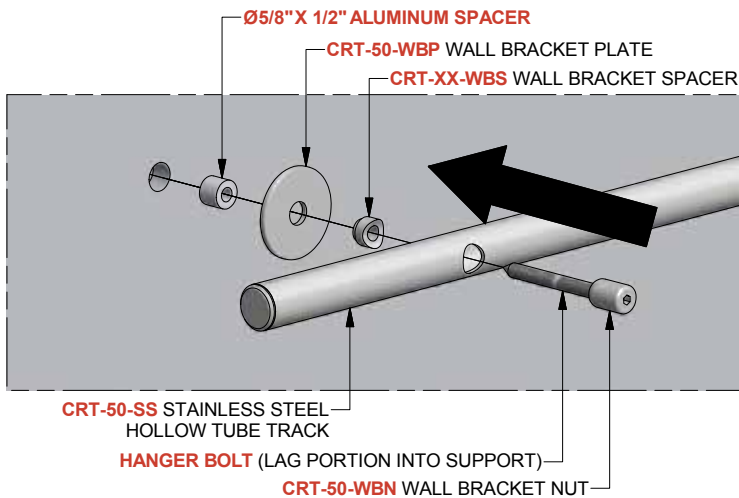
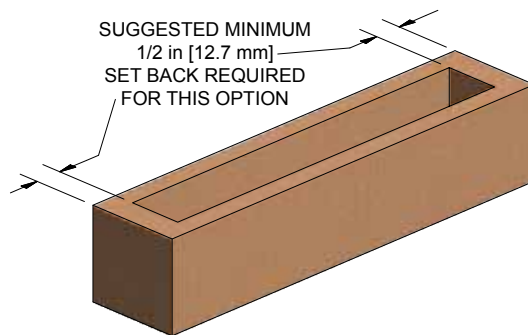

STEP #8:

PREPARE C-914 GUIDE CHANNEL SLOT IN DOOR AT LEAST 1" [25.4 mm] WIDE IN CENTER OF DOOR, AND AT LEAST 29/32" [23 mm] DEEP. IT IS RECOMMENDED TO MAKE THE SLOT AS ACCURATE AS POSSIBLE FOR SECURE FIT AND NEAT APPEARANCE. SEE BELOW:

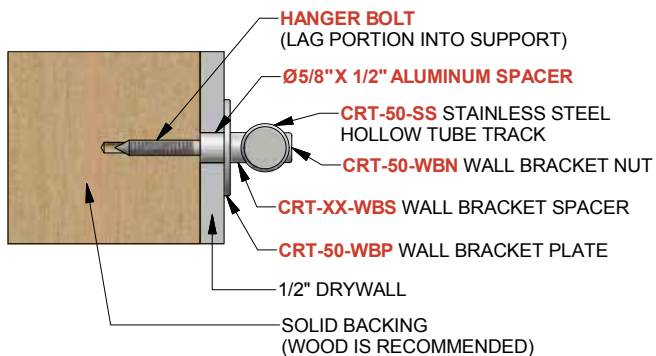
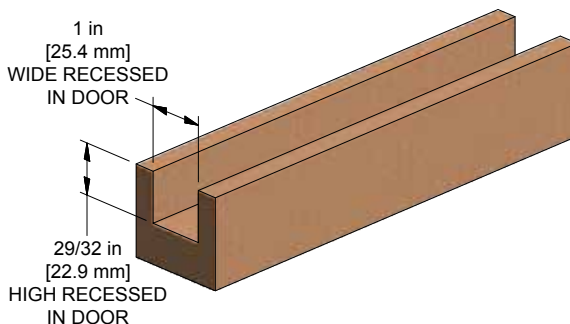

STEP #9:

CUT C-914 ALUMINUM GUIDE CHANNEL TO CORRECT LENGTH AS REQUIRED. DRILL HOLES IN C-914 GUIDE CHANNEL AND PRE-DRILL HOLES IN DOOR. LOCATE C-914 GUIDE CHANNEL IN SLOT AND SCREW CHANNEL INTO PLACE WITH #8 X 3/4" PAN HEAD SCREWS (4 SCREWS ARE PROVIDED IN KIT).

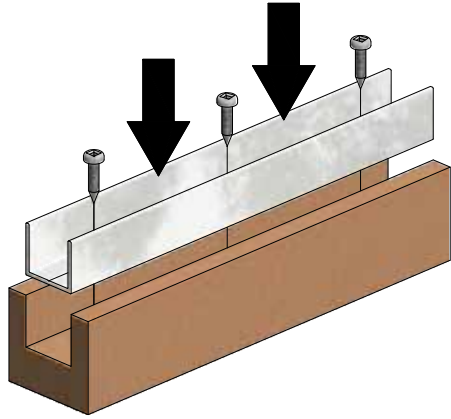

STEP #10:

INSTALL CRT-52-SS HANGER BODIES [H] ONTO THE DOOR [D] WITH CRT-50-CB-SS BOLTS [B] (4 FOR EACH HANGER) AND CRT-52-DR-SS (FOR 1-3/4" DOORS ONLY) OR CRT-52-DR38-SS (FOR 1-3/8" DOORS ONLY) DOOR RODS [R] (2 FOR EACH HANGER) AS SHOWN IN ILLUSTRATIONS BELOW:

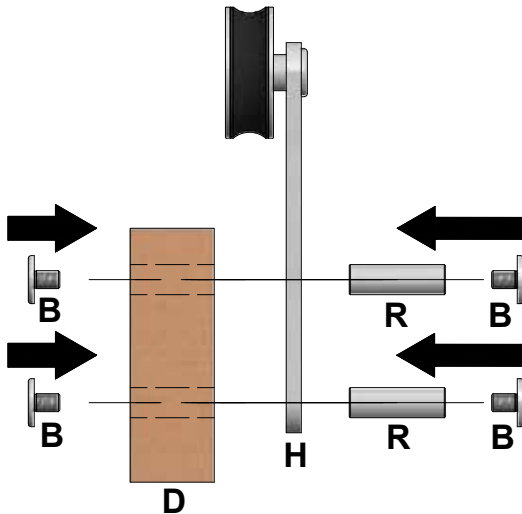
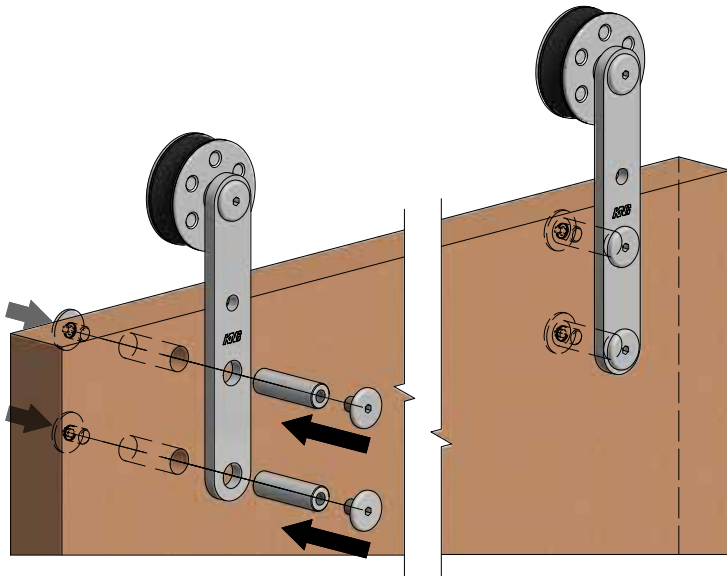

STEP #11:

LOCATE C-913 GUIDE AS PER REQUIREMENT BASED ON THE SUGGESTIONS BELOW AND SITE CONDITIONS. SECURE TO FLOOR WITH #10 X 1-3/4" FLATHEAD SCREWS (2).

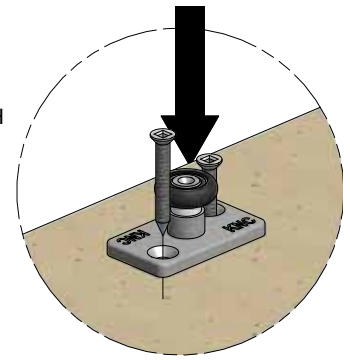

TYPICAL INSTALLATION

LOCATION FOR FLOOR GUIDES:

GUIDE CHANNEL IN DOOR WITH GUIDE ON FLOOR FOR BARN DOOR APPLICATIONS ILLUSTRATED BELOW:

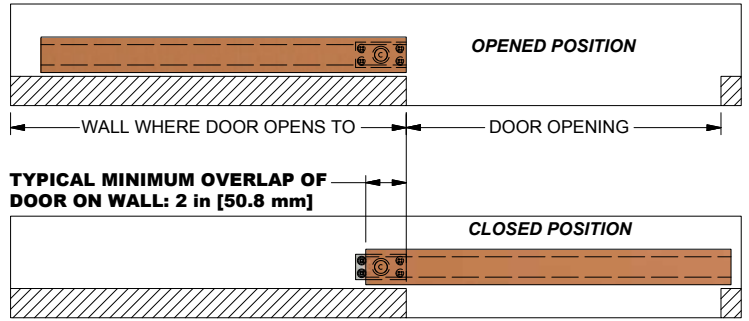

STEP #12:

PLACE DOOR ONTO TRACK. THE DELRIN WHEELS SHOULD BE RESTING ON THE TOP OF THE CRT-50-SS ROUND TUBE TRACK.

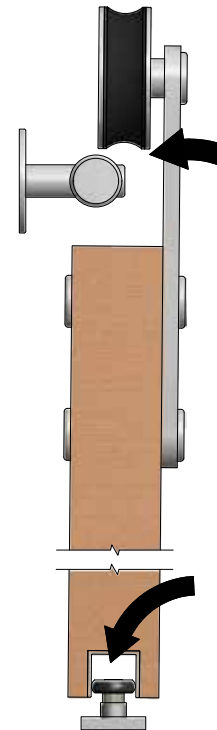
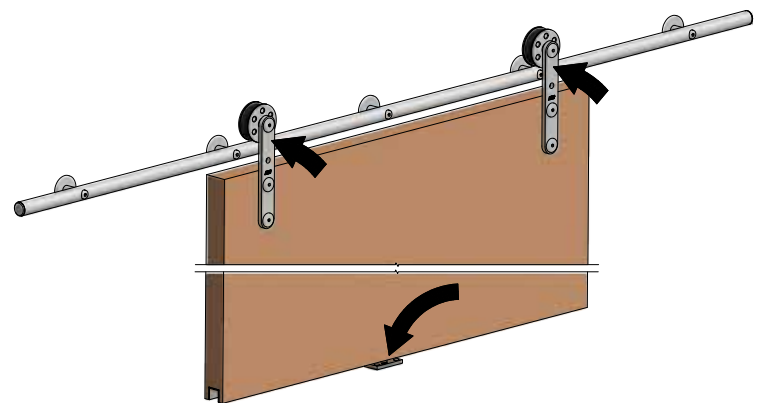

STEP #13:

PLACE THE CRT-50-SS SHOCK ABSORBING STOPS ONTO THE CRT-50-SS ROUND TUBE TRACK FROM THE ENDS OF THE TRACK. BEFORE YOU PLACE THEM ONTO THE TRACK, ENSURE THE SET SCREWS (SUPPLIED ON THE STOPS) ARE LOOSENED OFF. THE STOPS ARE REVERSIBLE.

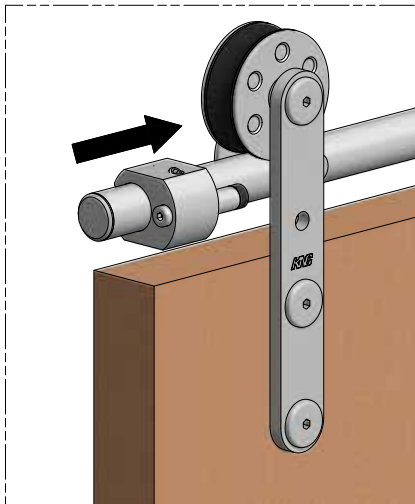

STEP #14:

POSITION THE STOPS AS REQUIRED TO LIMIT THE SLIDING DISTANCE OF THE DOOR. THE BUMPER ON THE STOPS SHOULD BE RESTING AGAINST THE SIDE OF THE HANGER BODY AS SHOWN BELOW. SECURE THE CRT-50-SS SHOCK ABSORBING STOPS TO THE TRACK WITH THE TWO SET SCREWS AS SUPPLIED. **NOTE: THE CRT-50-SS SHOCK ABSORBING STOPS MUST BE INSTALLED AS THIS WILL PREVENT THE DOOR FROM RUNNING OFF THE TRACK AND PROVIDE THE REQUIRED STOPPING FORCE FOR THE DOOR(S).**

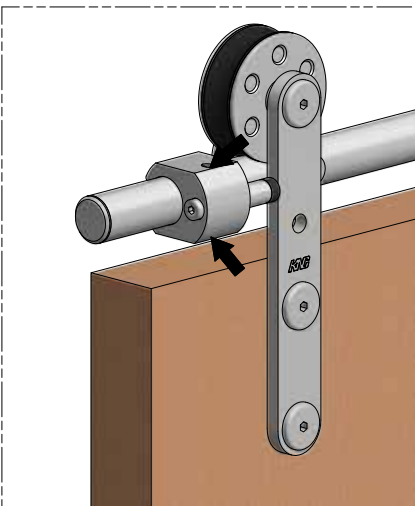

STEP #15:

ONCE THE DESIRED OPERATION OF THE SLIDING DOOR HAS BEEN ACHIEVED, INSTALL THE CRT-50-AL-SS ANTI-LIFT PIECE WITH A CRT-50-CB-SS BOLT C/W LOCTITE TAPE ON EACH HANGER AS SHOWN BELOW. USE 1/8 in ALLEN KEY IN THE SIDE HOLE ON THE ANTI-LIFT PIECE TO PREVENT IT FROM TURNING WHEN TIGHTENING THE BOLT ON THE FRONT OF THE HANGER.

NOTE: THE CRT-50-AL-SS ANTI-LIFT PIECE MUST BE INSTALLED AS THIS WILL PREVENT THE DOOR FROM DISENGAGING WITH THE TRACK AND FALLING DOWN.

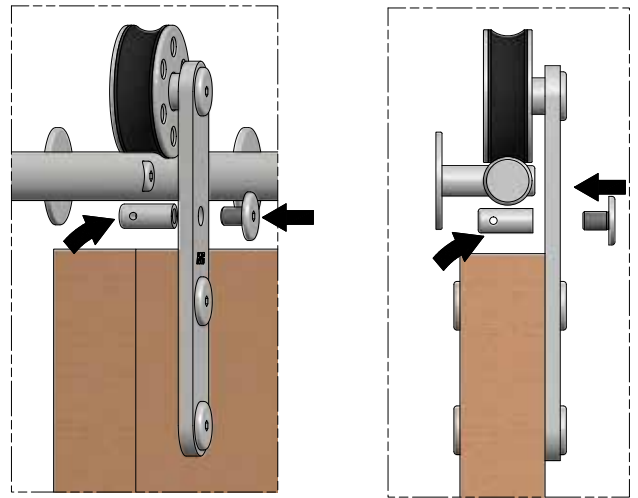

COMPLETED INSTALLATION END VIEW

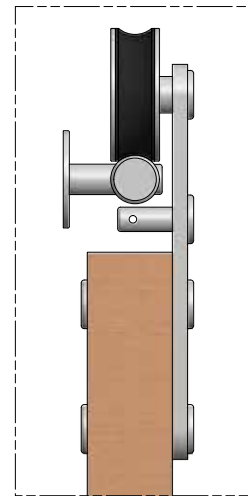

OPTIONAL PRODUCTS:

PLEASE VISIT OUR WEBSITE FOR OTHER OPTIONAL PRODUCT SUCH AS SIDE MOUNT GUIDES, DOOR LOCKS & PULLS AND MORE.

TROUBLESHOOTING:

ISSUE: IF CRT-50-SS STOPS ARE SLIDING

SOLUTION: ENSURE THE SET SCREWS ARE TIGHTENED TO CREATE A FRICTION FIT AROUND THE TRACK.

ISSUE: CHATTER/NOISE WHEN DOOR IS SLIDING.

SOLUTION: ENSURE THE HANGERS ARE FULLY SECURED TO THE DOOR AND THE TRACK IS FULLY SECURED TO THE SUPPORT.

ISSUE: TRACK IS SAGGING FROM THE WALL.

SOLUTION: ENSURE ADEQUATE SUPPORT IS PROVIDED IN THE WALL TO SUPPORT THE TRACK. ENSURE THE PROPER ANCHORS ARE BEING USED BASED ON THE SUPPORT CONDITIONS AND ENSURE THE TRACK IS FULLY SECURED TO THE SUPPORT.

CRFT-DS DRYWALL SPACER

INSTRUCTION SHEET



NEW PARTS SUPPLIED IN CRT & CFT SERIES KITS



CRFT-DS Ø1-5/8" X 1/2" ALUMINUM DRYWALL SPACER (X)
(SEE RESPECTIVE PRODUCT INSTRUCTION SHEETS FOR QUANTITY)



Ø5/8" X 1/2" ALUMINUM SPACER (X)
(SEE CHART A FOR QUANTITY BASED ON TRACK SIZE ORDERED)

OPTIONAL PARTS AVAILABLE SEPARATELY

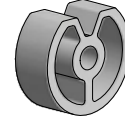

CRFT-DS Ø1-5/8" X 5/8" ALUMINUM DRYWALL SPACER (X)
(FOR 5/8" DRYWALL ONLY. PLEASE PURCHASE SEPARATELY)

REVISED STEPS:

AFTER MARKING A HORIZONTAL LINE WITH A LEVEL ON THE WALL AT THE MEASUREMENT AS PER THE RESPECTIVE PRODUCT INSTRUCTION SHEETS, LOCATE TRACK ON WALL AND MARK HOLE LOCATIONS AS PER THE SPACING STANDARDS BASED ON TRACK LENGTHS FOUND IN CHART A ON THE TEMPLATE SHEET OR WITH THE TRACK ON SITE.

ONCE THE HOLE LOCATIONS ARE MARKED, PRE-DRILL HOLES INTO THE WOOD SUPPORT AS REQUIRED ON THE RESPECTIVE PRODUCT INSTRUCTION SHEETS.

IF THERE IS DRYWALL PRESENT, PRE-DRILL A Ø1-5/8 in [41.3 mm] CLEARANCE HOLE IN THE DRYWALL PORTION OF THE HOLES ONLY. SEE ILLUSTRATIONS SHOWN TO THE RIGHT FOR ASSISTANCE.

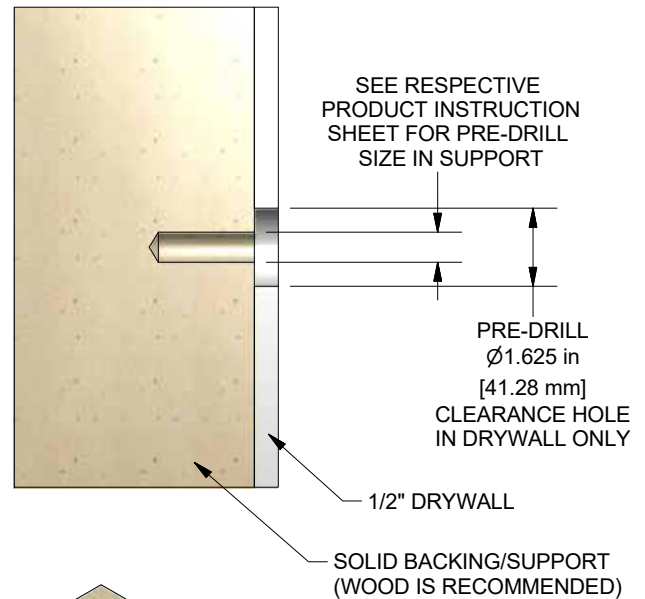

REVISED STEPS:

INSTALL TRACK ONTO WALL WITH THE NECESSARY COMPONENTS AND IN THE ORDER AS SHOWN ON THE RESPECTIVE PRODUCT INSTRUCTION SHEETS. THE ILLUSTRATIONS TO THE RIGHT IS BASED ON DRYWALL APPLICATION. **NOTE: ENSURE TRACK IS LEVELED AND FULLY SECURED TO THE SUPPORT.**

INSTALL THE CRFT-DS DRYWALL SPACERS WITH THE "V" GROOVE IN AN UPWARDS POSITION AS PER THE ILLUSTRATION TO THE RIGHT.

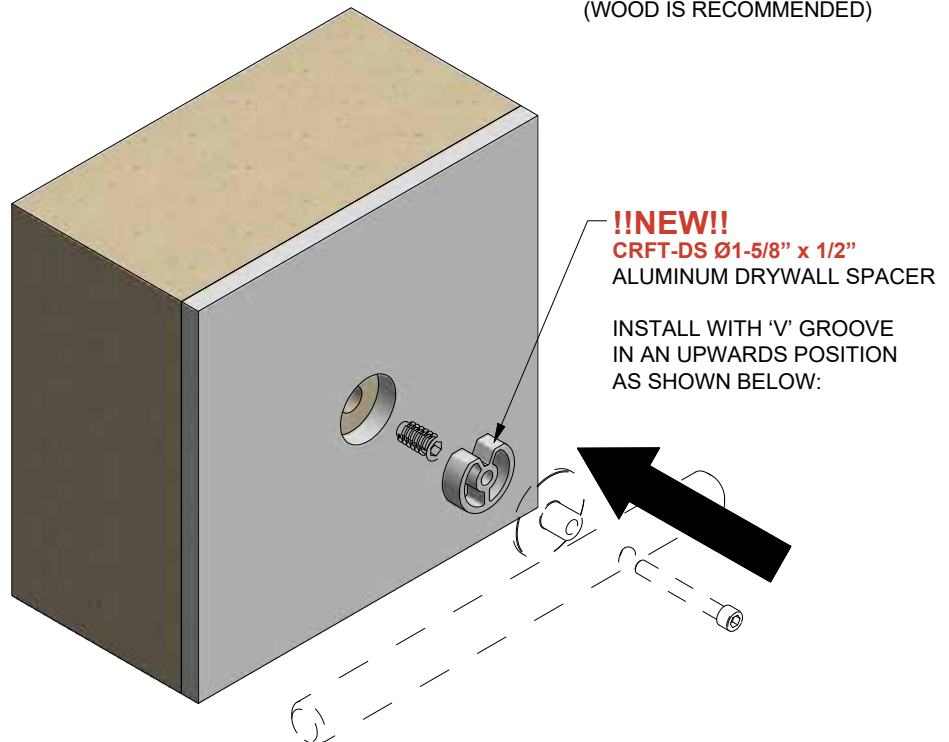

A PRODUCT OF K.N. CROWDER MFG. INC

CRT-52-SS SERIES HANGER HOLE LOCATION TEMPLATE

TEMPLATE SHEET



TRACK SIZE SPACING AND HOLE QUANTITY CHART AND DETAILS

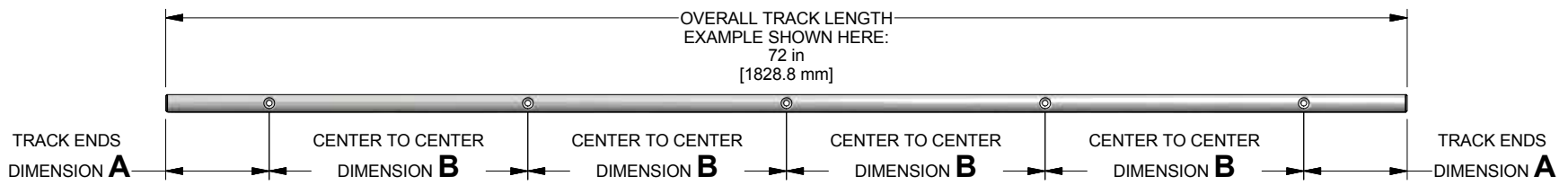

OVERALL TRACK LENGTH	NO. OF HOLES	DIMENSION A		DIMENSION B	
60 in [1524 mm]	4	6 in [152 mm]	16 in [406 mm]	6 in [152 mm]	16 in [406 mm]
64 in [1626 mm]	4	8 in [203 mm]	16 in [406 mm]	6 in [152 mm]	15 in [381 mm]
72 in [1829 mm]	5	6 in [152 mm]	15 in [381 mm]	6 in [152 mm]	16 in [406 mm]
76 in [1930 mm]	5	6 in [152 mm]	16 in [406 mm]	7 in [178 mm]	14 in [356 mm]
84 in [2134 mm]	6	8 in [203 mm]	16 in [406 mm]	6 in [152 mm]	16 in [406 mm]
96 in [2438 mm]	6	7 1/2 in [191 mm]	15 in [381 mm]	6 in [152 mm]	15 in [381 mm]
108 in [2743 mm]	7	6 in [152 mm]	16 in [406 mm]	8 in [203 mm]	16 in [406 mm]
120 in [3048 mm]	8	6 in [152 mm]	15 in [381 mm]	8 in [203 mm]	16 in [406 mm]
132 in [3353 mm]	9	6 in [152 mm]	16 in [406 mm]		
144 in [3658 mm]	9	8 in [203 mm]	16 in [406 mm]		

SEE STEP #6 ON THE CRT-52-SS INSTRUCTION SHEETS FOR DETAILS.

